

technical reprint R/P086



microphony in photomultipliers

microphony in photomultipliers

R M McAlpine and A G Wright, Electron Tubes Limited, Bury Street, Ruislip, Middlesex HA4 7TA, UK

technical reprint R/P086

abstract

Vibration caused by rotating equipment such as vacuum pumps, and shock, due to sudden impulses, are the main sources of microphonic effects in photomultipliers. Resonant vibrations in the dynode structure in the vicinity of the anode of the multiplier generate an unwanted current analogue at the anode.

Mathematical analysis based on a realistic model of the photomultiplier makes predictions on the magnitude of the effect and on the location of individual sources of resonance. Experiments are reported on that support the predictions of the model.

Practical guidance is given on how to minimise microphonic effects.

1 introduction

The unwanted noise effects of operating photomultipliers in severe environments are well known to users in the oil well logging industry. Even in considerably less harsh laboratory applications, such as mass spectrometry for example, vibration from a vacuum pump can generate serious microphonic effects in photomultipliers.

The availability of electronics with ever increasing sensitivity has promoted users to i) move towards tubes with fewer stages ii) use photomultipliers intended for high gain at low gain. Where shock and vibration is present considerations, i) and ii) can lead to poor performance.

The authors are unaware of any published work that explains the origin of microphonics in photomultipliers and hence there is no guidance on how to minimize these noise effects in such detectors. There are papers on reducing microphony in other devices which either detail mechanical damping or eliminate voltage differences between vibrating elements. Mechanical damping is appropriate for photomultipliers, however elimination of voltage differences between electrodes would destroy the gain

of the photomultiplier. We propose a theoretical model that predicts that right order of magnitude for the observed effects and also points to means of reducing microphonic noise in photomultipliers.

2 theoretical considerations

For photomultipliers with a discrete dynode electron multiplier, there is a series of capacitances associated with the anode and the individual dynodes. This is illustrated in **figure 1**. There are also inter-dynode capacitances but these are of no consequence in this analysis.

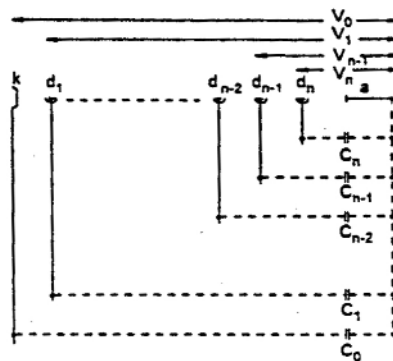

figure 1 illustrating anode to dynode capacitances in a discrete dynode photomultiplier.

Referring to **figure 1**, V_n is the potential difference between the n th dynode d_n and the anode; C_n is the corresponding capacitance. In the absence of vibration, the total charge stored in the anode-dynode system is

$$q = \sum_n C_n V_n \quad \dots(1)$$

If each C_n has an associated variable component C'_n induced by vibration of frequency ω , then

$$q(t) = \sum_n (C_n + C'_n \sin \omega t) V_n \quad \dots(2)$$

where $q(t)$ is the charge stored within the anode-dynode system under dynamic conditions.

The current flowing into the anode is

$$i(t) = \frac{dq(t)}{dt} = \sum_n V_n C'_n \omega \cos \omega t \quad \dots (3)$$

Where $V_n C'_n \omega$ is the amplitude of the n th induced current component.

The proposed equivalent circuit for a photomultiplier under vibration is given in **figure 2**. It consists of a set of current generators, one for each dynode, in parallel with the signal source $I(t)$. The magnitude of each current generator is given by the corre-

sponding element in the right hand side of equation (3).

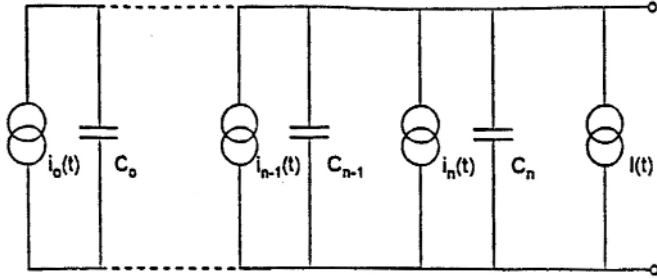

figure 2 the equivalent circuit for photomultiplier under vibration. The meaning of the symbols is given in the text.

In order to gain some idea of the magnitude of microphonic noise, consider \hat{i}_n , the peak current induced by vibrations occurring between the last dynode and the anode. Take $V_n = 100 \text{ V}$, $C_n = 5 \text{ pF}$ and assume that an impressed frequency of vibration of 1 kHz causes a 0.1% modulation ($5 f F$) of C_n , then

$$\hat{i}_n = 100 \times 5 \cdot 10^{-15} \times 2 \pi \cdot 10^3 \quad \dots(4)$$

$$\sim 3 \text{ nA}$$

With a gap of typically 5 mm between electrodes the movement is of the order of $5 \mu\text{m}$ for 0.1% change in capacitance. This illustrates how only a very small vibration can cause a significant induced current.

3 experimental verification

Electron Tubes' Acoustical Vibration Facility shown in figure 3, consists of a commercial, 1 watt, piezo electric transducer mounted in contact with the window of the photomultiplier under test. The loud-speaker is activated by a swept frequency sine wave generator covering the range 200 to 2000 Hz. Output is taken from the anode to a current-to-voltage amplifier followed by a second stage of voltage gain. In the high gain configuration, with a feedback resistor of 682 k Ω , the conversion gain is 0.9 volts output for 100 nA anode current. In the low gain setting with 62 k Ω feedback, the conversion gain is 0.1 volts per 100 nA anode current. Unless otherwise stated all results refer to the high gain configuration.

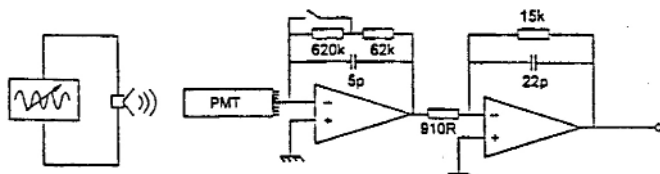

figure 3 the acoustical vibration facility used to locate resonant frequencies and measure microphonic currents produced in photomultipliers.

The photomultipliers used in this study are 9106B, 30 mm, 7 stage, linear focused types. Figure 4 shows chart recordings measured at the output of the amplifier. Each photomultiplier was measured at 1 A/lm (gain of $\sim 10^4$) in a linear divider which provided an equal distribution of about 50 V per stage.

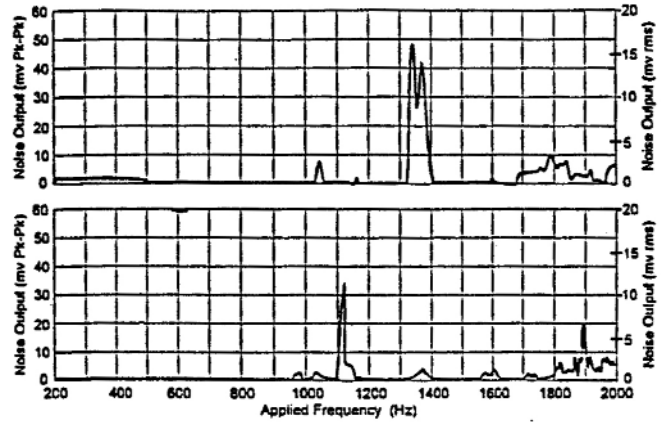

figure 4 the output of a 9106B photomultiplier when acoustically excited. The upper curve is #34390 and the lower #34408 operated at 430 and 469 volts, respectively.

There are several points to note here:

Resonances occur at different frequencies although the photomultipliers are of the same type.

The magnitude of the peaks is 10 to 15 mV rms which corresponds to 1 to 1.5 nA rms anode current.

The results of figure 4 give no indication as to the dynode or dynodes responsible for the particular peaks. In order to determine this, a second series of experiments was done in which the dynodes were successively brought into action.

In figure 5(a) only d_7 is active through the application of -100 V with respect to the anode. All other dynodes were at 0 V. The flat trace shows little evidence of resonances attributable to d_7 over the frequency range of interest.

In figure (5b) d_7 has -100 V and d_6 has -200 V applied with all other dynodes at 0 V. We can thus ascribe the peaks at 1050, 1650 and 1920 Hz to d_6 .

Figures 5(c) and 5(d) were obtained by successively activating d_5 and d_4 as described above. We note that d_5 produces no peaks of any consequence but that d_4 gives rise to peaks at 690, 1250 and a doublet at 1350 Hz.

Using the same sequence of measurements we were able to show for #34408 that the peak at 1110 Hz is due to d_4 .

5 system gain consideration

It has been shown that microphonic noise from a particular dynode varies in proportion to the voltage applied to that dynode. The amplitude of the total microphonic noise from all dynodes will thus vary in proportion to the overall voltage applied to the tube. However, the gain of a photomultiplier does not increase linearly with applied voltage but varies as a high power. Although the microphonic noise increases, the signal derived from the photocathode increases much more rapidly with overall voltage. For best signal to noise, the prediction is that the photomultiplier should be operated at high gain with the external amplifier gain reduced to give the required overall sensitivity. This is verified in **figure 7** which shows the results of operating photomultiplier #34390 at a gain of 10^4 by using a feedback resistor of $682\text{ k}\Omega$ and then at gain 10^5 with a feedback resistor of $62\text{ k}\Omega$.

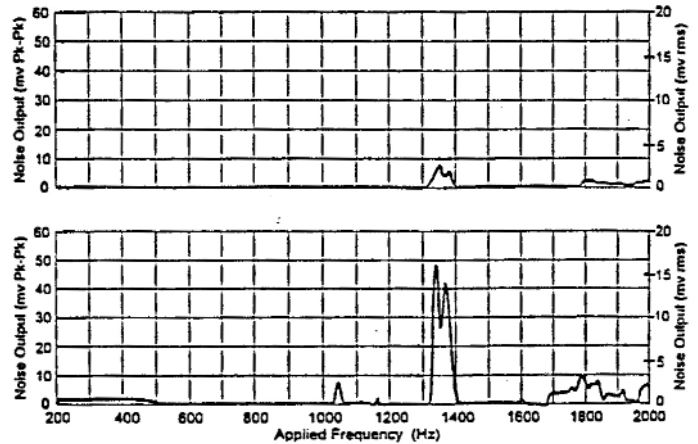

figure 7 illustrating that a photomultiplier operated in a severe shock and vibration environment gives best performance when operated at high gain. The upper trace refers to a photomultiplier gain of 10^5 (HV = 655 V) and the amplifier at $1\text{ V}/\mu\text{A}$ and the lower to a gain of 10^4 (HV = -430 V) with an amplifier gain of $10\text{ V}/\mu\text{A}$. Note the system gain is the same in both cases.

6 conclusions

This investigation shows that the model proposed for explaining microphonic noise in photomultipliers is substantially correct.

For the photomultiplier type investigated in this work it is shown that the origin of the noise derives from d_6 and even d_4 . Further work is in progress on additional samples and to establish whether even earlier dynodes contribute.

The magnitude of the contribution from the individual dynode is proportional to the voltage applied to that dynode.

Best performance is obtained, in applications where severe shock and vibration are present, by operating the photomultiplier at high gain.

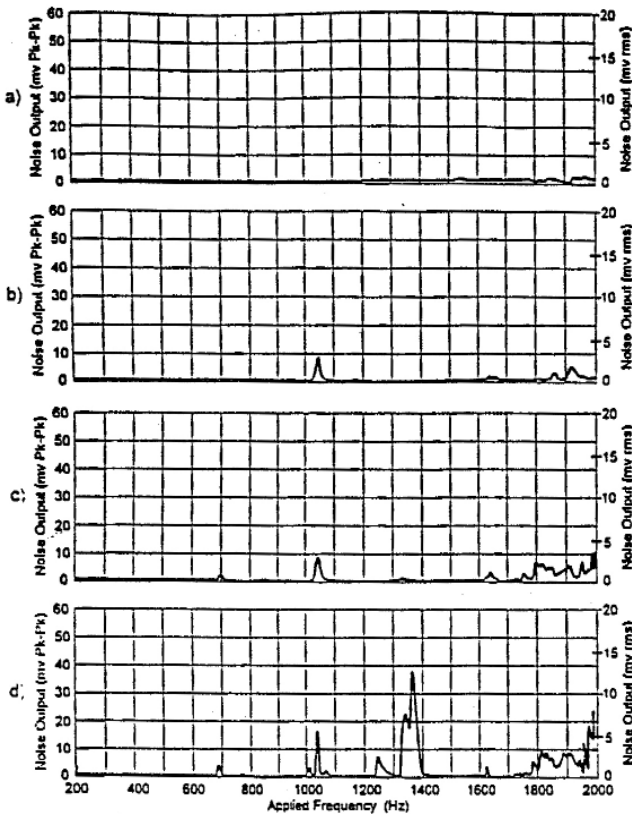

figure 5 by successively applying voltage to the dynodes it is possible to isolate the dynode responsible for a particular resonance peak. The dominant peaks apparent here are due to d_6 and d_4 .

- d_7 at -100 V
- d_7 at -100 V and d_6 at -200 V
- d_7 at -100 V, d_6 at -200 V and d_5 at -300 V
- d_7 at -100 V, d_6 at -200 V, d_5 at -300 V and d_4 at -400 V

4 voltage dependence

Equation (3) predicts that the amplitude of the induced current from d_n is proportional V_n , the voltage between d_n and the anode. This was verified for #34390 by recording noise traces with d_4 voltage successively increased from -100 to -500 V with all other electrodes at 0 V. Although there is scatter on the results, **figure 6** verifies that the microphonic noise varies proportionally with the voltage applied between the particular dynode and the anode.

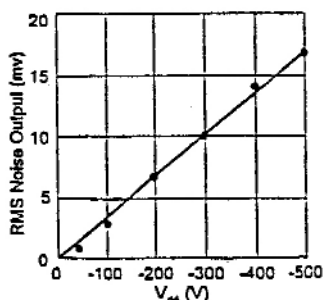

figure 6 the microphonic noise varies proportionally with applied voltage. V_{d4} is the voltage applied to d_4 with all other electrodes at 0 V in #34390.

Electron Tubes Limited

Bury Street, Ruislip

Middx HA4 7TA, UK

Tel: +44 (0)1895 630771

Fax: +44 (0)1895 635953

Email: info@electron-tubes.co.uk

Electron Tubes Inc.

100 Forge Way, Unit F

Rockaway, NJ 07866, USA

Tel: (973)586 9594

Toll free: (800)521 8382

Fax: (973)586 9771

Email: sales@electrontubes.com

www.electrontubes.com

**Contact us today we have a
world-wide network of agents
and distributors.**

talk to us about your
application or choose a product
from our literature:

photomultipliers & voltage dividers

light detector assemblies

electronic modules

housings

X-ray detector modules

power supplies